

SC-9 Cap

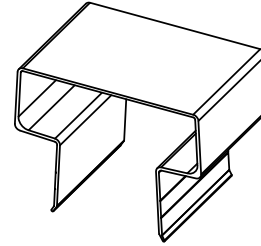

Section Modulus (Z)	8.2 in ³	134 cm ³
Moment of Inertia (I)	35 in ⁴	1,457 cm ⁴
Outside Width	8.5 in	216 mm
Inside Width	4.25 in	108 mm
Material	6061-T6 Marine Grade Aluminum	
Sheet Piling Compatibility	AWM-3, AWM-8, PZM-16, PZM-19	
Tie Rod Compatibility	SC-9 Rod Kit, AW 2.5" x 0.75" Rod Kit, AW 2.9" x 1" Rod Kit	
Recommended Accessories	45° and 90° SC-9 Corner Insert	
Standard Colors	Mill Finish	
Standard Packaging	25ft SC-9 Cap, SS and Nylon Fasteners, Splice Insert	

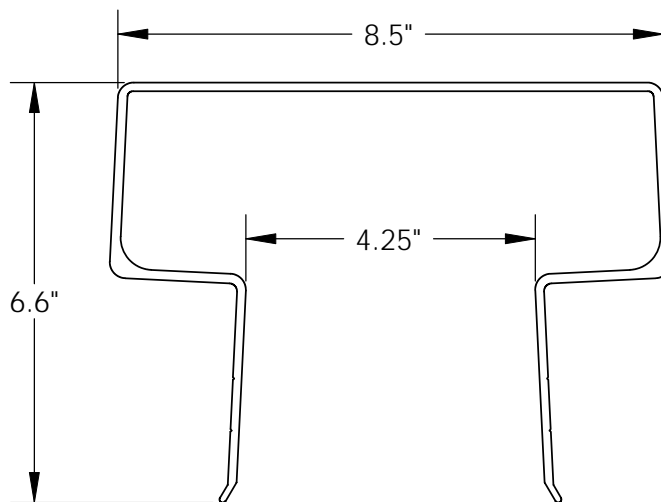

Physical properties are defined by ASTM testing standards, The Aluminum Association Design Manual, The Naval Facilities Design Manual DM 7.2, The US Army Corps of Engineers General Design Guide: PVC Sheet Pile and/or standard engineering practice. The values shown are nominal and may vary. The information found in this document is believed to be true and accurate. No warranties of any kind are made as to the suitability of any CMI product for particular applications or the results obtained there from. Crane Materials International is a Crane Building Products® company. ShoreGuard®, The ShoreGuard Seawall System™, C-Loc®, TimberGuard®, GeoGuard®, Dura Dock®, Shore-All®, GatorGates®, GatorDock Elite™, ArmorWare™, ArmorRod™, Box Profile™, UltraComposite™, Elite Wall™, Elite Panel™, Elite Fascia Panel™, Flat Panel™, XCR™, XCR Technology™, XCR Vinyl™, GatorBridge™, Gator Aluminum™, Gator Sheet Piling™, GatorDock™, I-Beam Lock™, Textured Slate™, Crane Materials International™ logo, CMI Sheet Piling Solutions™, Aqua Terra System™, Endurance™, Endurance CSPTM, Palaris™, Eclipse™, GridSpine™, 21 Poly™, PileClaw™, SheerScape™, SheerScape Retaining Wall Systems™, Sheer Panel™ and CMI Waterfront Solutions™ are trademarks, service marks or trade names of Crane Materials International. United States and International Patent numbers 4,674,921; 4,690,588; 5,292,208; 5,145,287; 6,000,883; 6,033,155; 6,053,666; D420,154; 6,575,667; 7,059,807; 7,056,066; 7,025,539; 7,393,482; 5,503,503; 5,803,672; 6,231,271; 1,245,061CA and other patents pending. © 2011 Crane Materials International. All Rights Reserved.