

REVISIONS				
ZONE	REV	DESCRIPTION	DATE	APPROVED

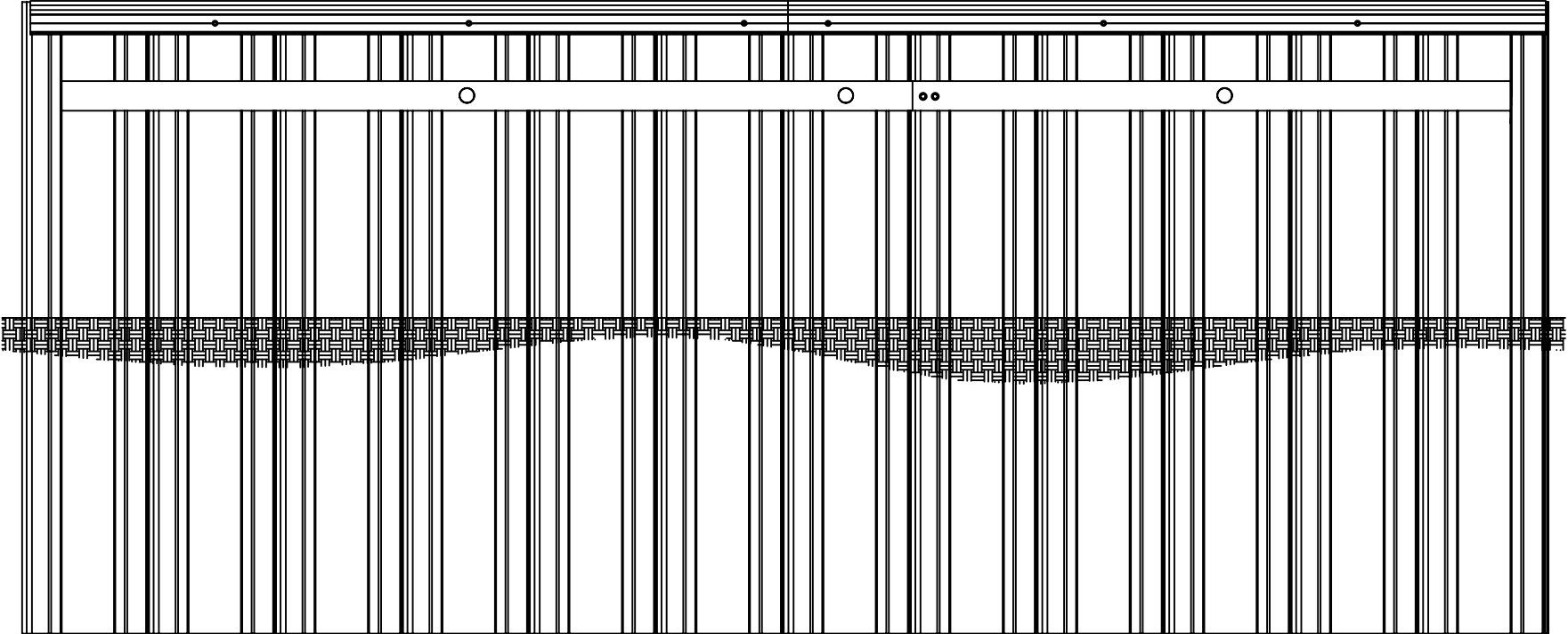

The configurations shown are considered typical and for budgetary purposes only. Please rely on your engineer for specific design recommendations. Because of the complexity of geotechnical loading calculations and the susceptibility to extreme change of soil loads with minor changes in local site conditions such as soil parameters, water levels, surcharge loads, etc., we strongly recommend the use of design professionals who are familiar with local wall construction to determine the required sheet piling and component capacities. The material contained within this drawing is not to be used for any project specific design.



CRANE MATERIALS INTERNATIONAL

### Drop Wale Standard Drawing- Front Elevation

SIZE A	DATE 05/24/05	FILE	REV REL
SCALE N/A	DRAWN CBB	SHEET 1 of 3	

REVISIONS				
ZONE	REV	DESCRIPTION	DATE	APPROVED

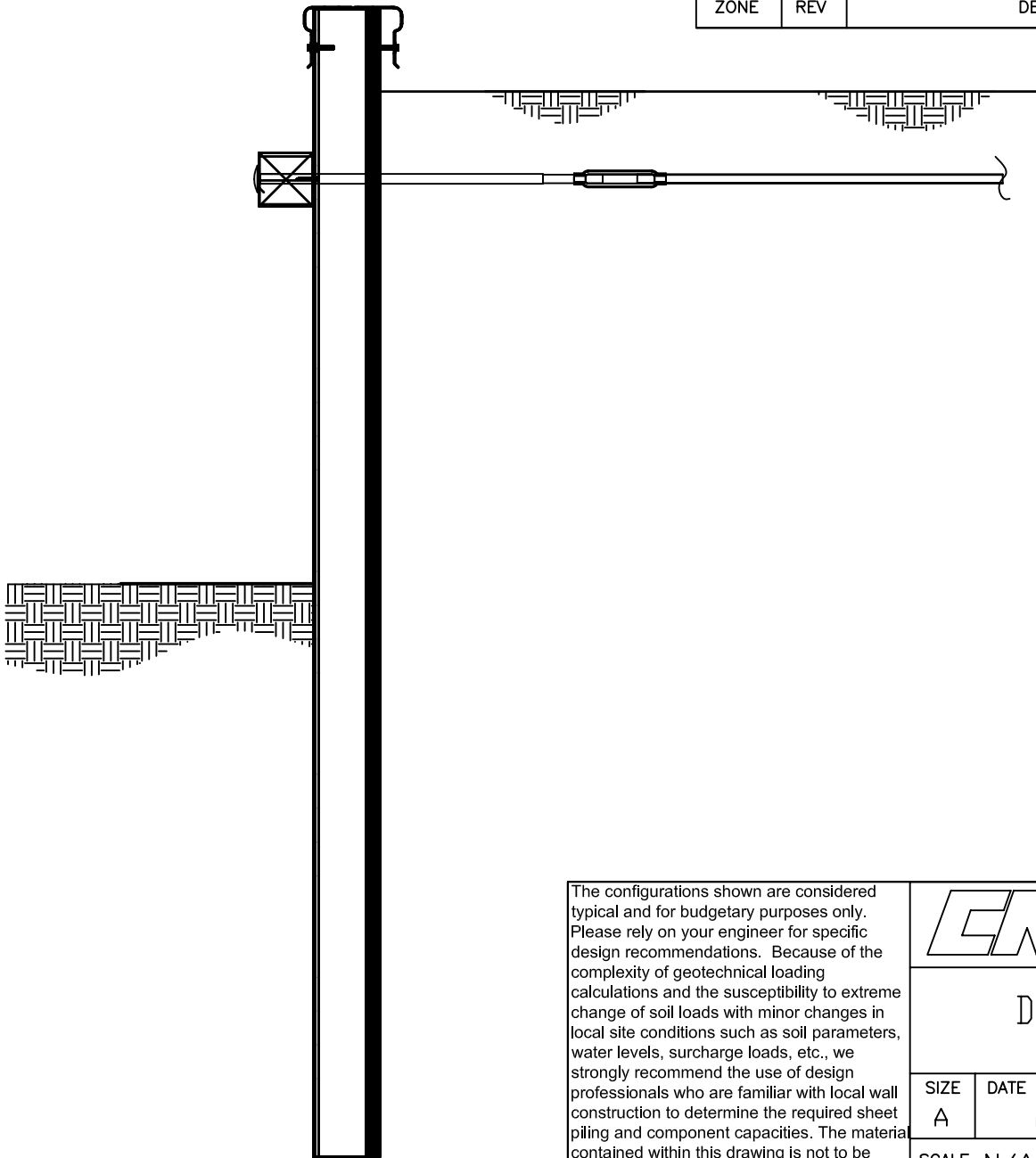

The configurations shown are considered typical and for budgetary purposes only. Please rely on your engineer for specific design recommendations. Because of the complexity of geotechnical loading calculations and the susceptibility to extreme change of soil loads with minor changes in local site conditions such as soil parameters, water levels, surcharge loads, etc., we strongly recommend the use of design professionals who are familiar with local wall construction to determine the required sheet piling and component capacities. The material contained within this drawing is not to be used for any project specific design.



CRANE MATERIALS INTERNATIONAL

### Drop Wale Standard Drawing- Side Elevation

SIZE A	DATE 05/24/05	FILE	REV REL
SCALE N/A	DRAWN CBB	SHEET 2 of 3	

REVISIONS				
ZONE	REV	DESCRIPTION	DATE	APPROVED

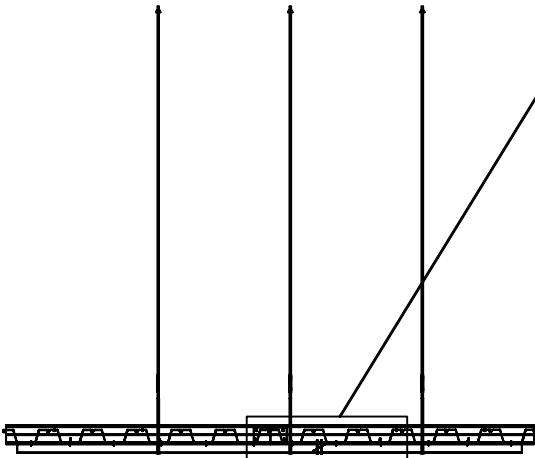
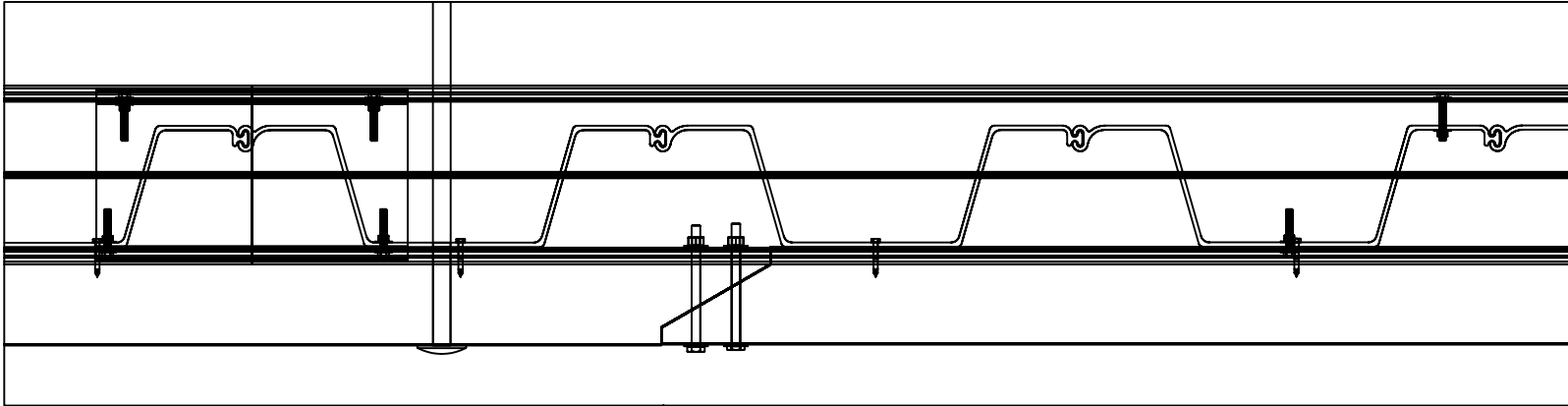

The configurations shown are considered typical and for budgetary purposes only. Please rely on your engineer for specific design recommendations. Because of the complexity of geotechnical loading calculations and the susceptibility to extreme change of soil loads with minor changes in local site conditions such as soil parameters, water levels, surcharge loads, etc., we strongly recommend the use of design professionals who are familiar with local wall construction to determine the required sheet piling and component capacities. The material contained within this drawing is not to be used for any project specific design.



CRANE MATERIALS INTERNATIONAL

Drop Wale Standard Drawing-  
Top Plan View

SIZE A	DATE 05/24/05	FILE	REV REL
SCALE N/A	DRAWN CBB	SHEET 3 of 3	